

SHARP®

FP-J40E FP-J40L FP-J40M



HIGH-DENSITY 7000*

“Plasmacluster” and “Device of a cluster of grapes” are registered trademarks of Sharp Corporation in Japan, Philippines and elsewhere.



*The number in this technology mark indicates an approximate number of ions supplied into air of 1 cm³, which is measured around the center of a room with the “high-density plasmacluster 7000” applicable floor area (at 1.2 m height above the floor) at the medium wind volume in air purifying mode, when an air purifier using the high-density plasmacluster ion evolving device is placed close to a wall. This product is equipped with a device corresponding to this capacity.

Free standing type
Jenis berdiri sendiri
Kiểu máy có chân tự đứng
站立式

**AIR PURIFIER
OPERATION MANUAL**

ENGLISH

**PEMBERSIH UDARA
BUKU PANDUAN OPERASI**

MALAYSIA

**HƯỚNG DẪN SỬ DỤNG MÁY
NĂNG BẮT MUỖI**

TIẾNG VIỆT

空气净化器操作手册

中文

Please read before operating your new Air Purifier

The air purifier draws in room air from the air intake, passes the air through a Pre-Filter, a Deodorizing Filter and a HEPA Filter inside of the main unit, then discharges the air through the air outlet. The HEPA Filter can remove 99.97% of dust particles as small as 0.3 microns that pass through the filter and also helps absorb odors.

The Deodorizing Filter gradually absorbs odors as they pass through the filter.

Some odors absorbed by the filters may break down over time, resulting in additional odor. Depending on the usage environment, especially when the product is used in extreme environments (significantly more severe than normal household use), this odor may become strong in a shorter period than expected. If the odor persists, the filters should be replaced.

NOTE

- The air purifier is designed to remove air-suspended dust and odor, but not harmful gases (for example, carbon monoxide contained in cigarette smoke). If the source of the odor still exists, the air purifier may not completely remove the odor.

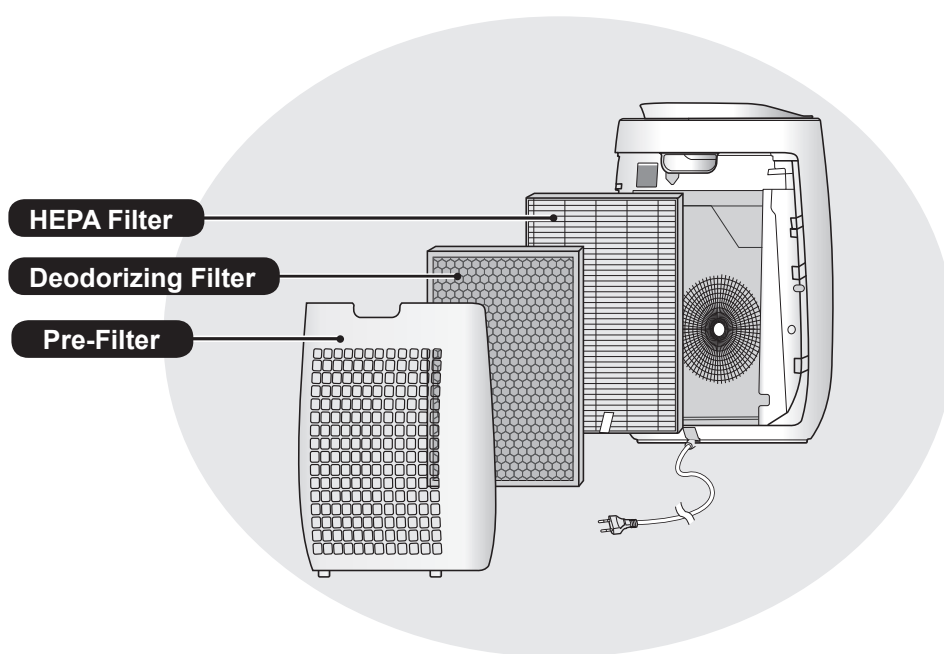

FEATURES

Unique Combination of Air Treatment Technologies
Triple Filtration System + Plasmacluster

TRAPS DUST*

Pre-Filter traps dust and other large airborne particles.

DECREASES ODORS

Deodorizing filter absorbs many common household odors.

REDUCES POLLEN & MOLD*

HEPA filter traps 99.97% of particles as small as 0.3 microns.

FRESHENS

Plasmacluster treats the air similar to the way nature cleans the environment by emitting a balance of positive and negative ions.

*When air is drawn through the filter system.

Sensor Technology continuously monitors air quality, and automatically adjusting operation based on detected air purity.

CONTENTS

IMPORTANT SAFETY INSTRUCTIONS	EN-2
PART NAMES	EN-4
FILTER INSTALLATION	EN-5
OPERATION	EN-6
CARE AND MAINTENANCE	EN-8
REPLACEMENT	EN-9
TROUBLESHOOTING	EN-10
SPECIFICATIONS	EN-11

Thank you for purchasing the SHARP Air Purifier. Please read this manual carefully. Before using this product, be sure to read the section: "Important Safety Instructions." After reading this manual, keep it in a convenient location for future reference. For your reference, we recommend to keep this manual in the place where you can read at any time.

IMPORTANT SAFETY INSTRUCTIONS

When using electrical appliances, basic safety precautions should be followed, including the following:

WARNING - To reduce the risk of electrical shock, fire or injury to persons:

- Read all instructions before using the main unit.
- Use only a 220-240 volt outlet.
- **Do not use the main unit if the power cord or plug is damaged or the connection to the wall outlet is loosened.**
- Periodically remove dust from the power plug.
- **Do not insert fingers or foreign objects into the intake or air outlet.**
- **When removing the power plug, always hold the plug and never pull the cord.**
Electrical shock and/or fire from short circuit may occur as a result.
- Be careful not to damage the power cord, it may cause electric shock, excess heat or fires.
- **Do not remove the plug when your hands are wet.**
- **Do not use this unit near gas appliances or fireplaces.**
- **Remove the power plug from the wall outlet before cleaning the main unit and when not using the main unit.**
Electrical shock from bad insulation and/or fire from short circuit may occur as a result.
- When cleaning the main unit, or when the main unit is not in use, be sure to unplug the main unit. Electrical shock and/or fire from a short circuit may result.
- **If the power cord is damaged, it must be replaced by the manufacturer, its service agent, Sharp Approved Service Center or similarly qualified person in order to avoid a hazard.**
- Do not operate when using aerosol insecticides or in rooms where there is oily residue, incense, sparks from lit cigarettes, chemical fumes in the air or in very high humidity conditions, such as a bathroom.
- Be cautious when cleaning the main unit. Corrosive cleansers may damage the exterior.
- Only a Sharp Authorized Service Center should service this air purifier. Contact the nearest Service Center for any problems, adjustments, or repairs.
- **This appliance is not intended for use by persons (including children) with reduced physical, sensory or mental capabilities, or lack of experience and knowledge, unless they have been given supervision or instruction concerning use of the appliance by a person responsible for their safety. Children should be supervised to ensure they do not play with the appliance.**

NOTE - Radio or TV Interference

If this air purifier should cause interference to radio or television reception, try to correct the interference by one or more of the following measures:

- Reorient or relocate the receiving antenna.
- Increase the separation between the main unit and radio/TV/wave-clock receiver.
- Connect the equipment into an outlet on a circuit different from that to which the receiver is connected.
- Consult the dealer or an experienced radio/TV technician for help.

CAUTIONS CONCERNING OPERATION

- Do not block the intake and/or air outlet.
- Do not use the unit near or on hot objects, such as stoves or heaters or where it may come into contact with steam.
- Do not lay the unit down when using.
- **Always hold the handle on the back of the unit when moving it.**
- Do not use without the filters inside the unit.
- **Do not wash and reuse the HEPA filter and the deodorizing filter.**
Not only does it not improve filter performance, it may cause electric shock or malfunction.

INSTALLATION GUIDELINES

- **When using the unit, place it away from equipment utilizing electric waves such as televisions or radios to avoid electrical interference.**
- **Avoid use in locations where furniture, fabrics or other items may come in contact with and restrict the air intake and/or air outlet.**
- **Avoid use in locations where the unit is exposed to condensation or drastic temperature changes. Appropriate conditions are when room temperature is between 0 – 35 °C.**
- **Place on a stable surface with sufficient air circulation.**
When placing the unit on a heavily carpeted area, the unit may vibrate slightly.
- **Avoid locations where grease or oily smoke is generated.**
The unit surface may crack as a result.
- The dust collecting ability of the unit is effective even when the unit is as close to 3 cm from the wall, the surrounding walls and floor may get dirty. Please place the unit at a distance from the wall. The wall directly behind the air outlet may become dirty over time. When using the unit for an extended period of time at the same location, periodically clean the walls adjacent to it.

FILTER GUIDELINES

- Follow the instructions in this manual for correct care and maintenance of the filter.

PART NAMES

FRONT

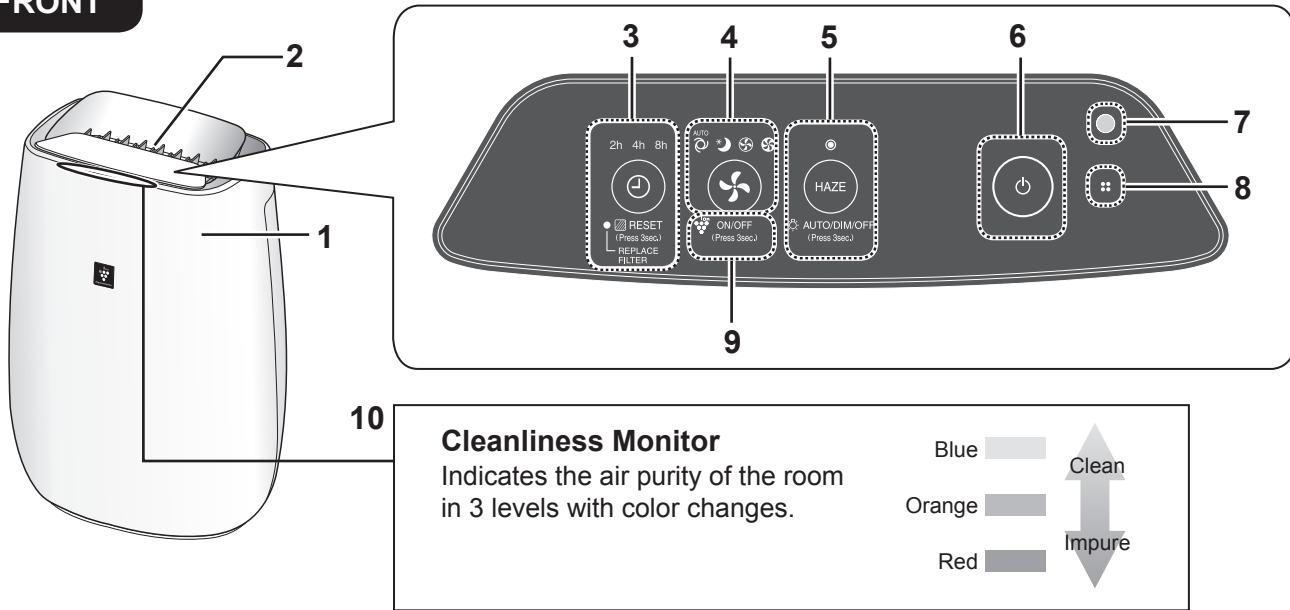

BACK

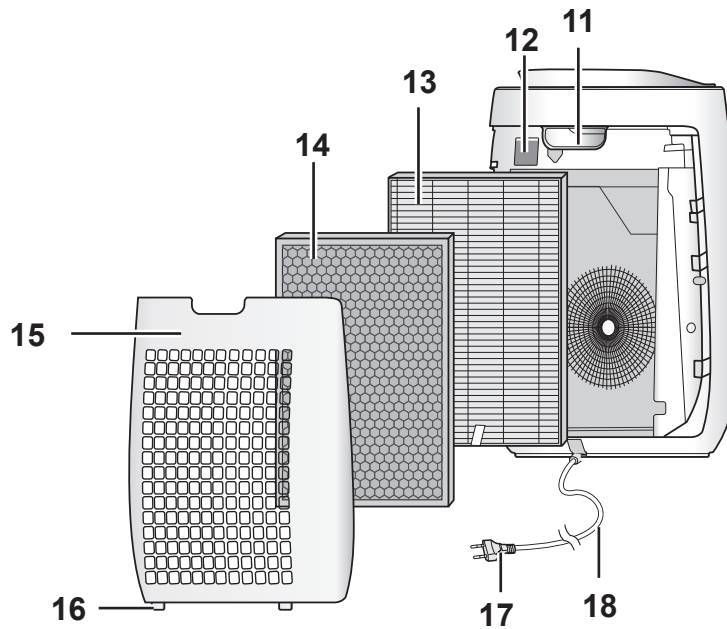

1	Main Unit	10	Cleanliness Monitor
2	Air Outlet	11	Handle
3	OFF TIMER Button, Indicator Light (white) (Press 3 sec.) Filter Reset Button, Indicator Light (orange)	12	Dust Sensor Filter
4	MODE Button, Indicator Light (white) (Press 3 sec.) Plasmacluster Ion ON/OFF Button	13	HEPA Filter
5	HAZE Button, indicator Light (white)	14	Deodorizing Filter
6	POWER ON/OFF Button	15	Back Panel (Pre-Filter)
7	Light Sensor	16	Bottom Tabs
8	Odor Sensor	17	Plug (Shape of plug depends on country.)
9	Plasmacluster Ion Light (blue)	18	Power Cord

FILTER INSTALLATION

Be sure to remove the power plug from the wall outlet.

To maintain the quality of the filter, it is installed in the main unit and packed in plastic bag. Be sure to remove plastic bag from the filter before using the unit.

ENGLISH

1 Remove the Back Panel.

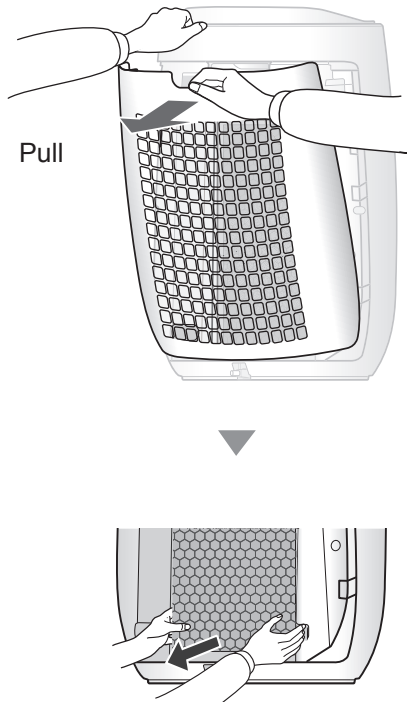

2 Remove the plastic bag from the Filter.

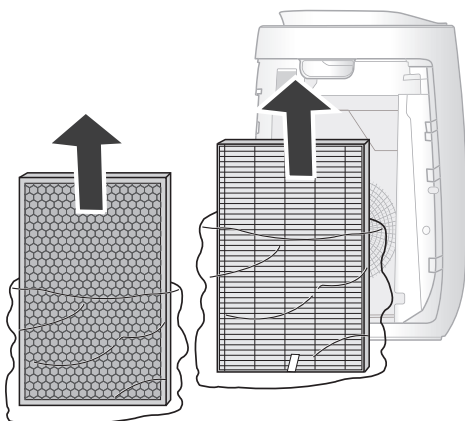

3 Place the Filter within the main unit.

Do not install the filter backwards or the unit will not operate properly.

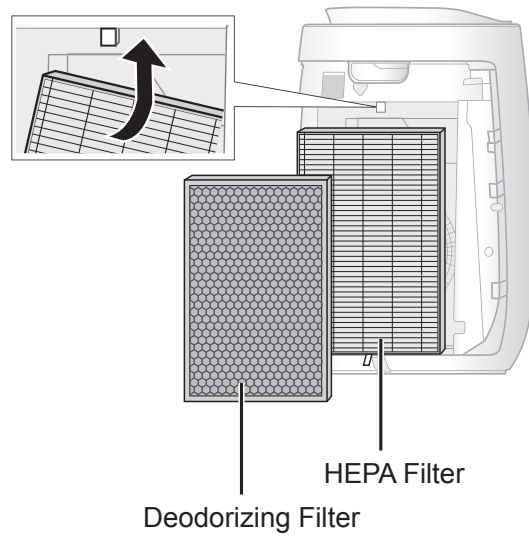

4 Replace the Back Panel to the main unit.



• Do not operate the unit without the filter.

OPERATION

START/STOP

START



STOP

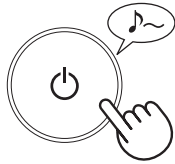

- Select the desired fan speed.
- When the main unit starts operation, the operation starts in the previous mode it was operated in.

HAZE

The unit operates at HIGH fan speed for 60 minutes and then alternates between Low and High level for 20 minutes each.

START



10 minutes: Max High fan level
50 minutes: High fan level
20 minutes: Low fan level
20 minutes: High fan level

NOTE

- The Plasmacluster Ion can not be turned "OFF".
- It is possible to switch this mode to another while operating. However, the HAZE mode will not function after switching mode.

FAN SPEED



NOTE

AUTO

The fan speed is automatically switched depending on the amount of impurities in the air. The sensors detect impurities for efficient air purification.

SLEEP

The unit will operate very quietly, and the fan speed is automatically switched depending on the amount of impurities in the air. Cleanliness Monitor/Plasmacluster Ion Light go off automatically. Even though the indicator is off, Plasmacluster Ion is dispersed into air unless Plasmacluster Ion is turned off by

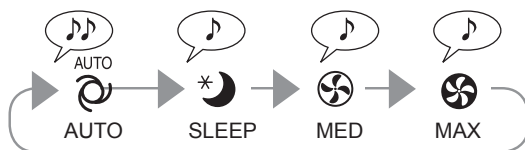

OFF TIMER

Select the length of time you want, with the main unit on. The main unit automatically stops once the selected time is reached.

(with the main unit ON)

2h 4h 8h

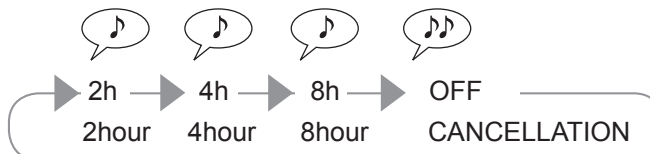
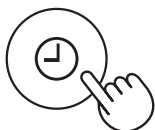

Light Control

You can set the Cleanliness Monitor / Plasmacluster Ion Light to OFF when their SIGN is bright.

1 (with the main unit ON)

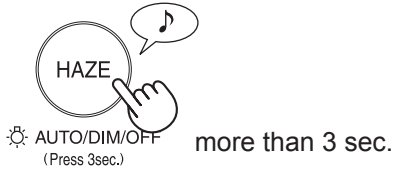

NOTE

- When the main unit starts operation, the operation starts in the previous mode it was operated in.

2

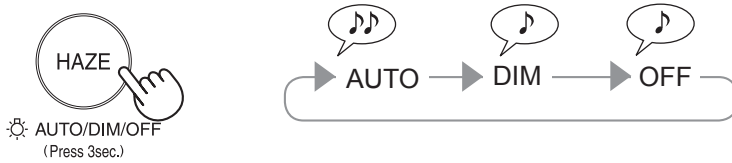

Plasmacluster Ion ON/OFF

When Plasmacluster Ion is ON, the Plasmacluster Ion Light will turn on. (blue)

(with the main unit ON)

ON



OFF



NOTE

- When the main unit starts operation, the operation starts in the previous mode it was operated in.

ADJUSTMENT OF SENSOR DETECTION SENSITIVITY

You can change the sensitivity of the Dust sensor / Odor sensor and the Light sensor .

1 (with the main unit OFF)



2

Dust sensor / Odor sensor

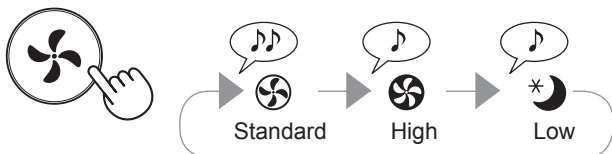

Light sensor

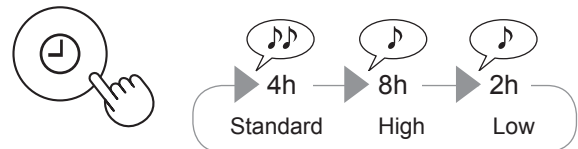

3

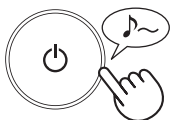

NOTE

- If the power OFF Button is not pushed within 8 seconds of adjusting sensor sensitivity, the setting will be saved automatically.
- The sensor sensitivity setting will be saved even if the main unit is unplugged.

CARE AND MAINTENANCE

Be sure to remove the power plug from the wall outlet.



To maintain optimum performance of this air purifier, please clean the unit including the filter periodically. Be sure to disconnect the power cord from the wall outlet before performing any maintenance.

BACK PANEL (Pre-filter)

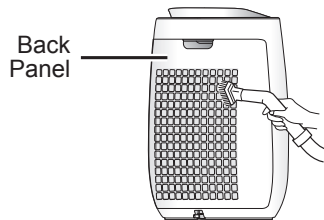

Gently remove dust from the back panel, using a vacuum cleaner attachment or similar tool.

CAUTION

Do not apply excessive pressure, when scrubbing the back panel.

NOTE How to clean hard to remove dirt

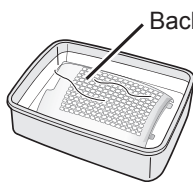

1. Add a small amount of kitchen detergent to water and soak for about 10 minutes.
2. Rinse off the kitchen detergent with clean water.
3. Completely dry the filter in a well-ventilated area.

FILTERS

HEPA Filter

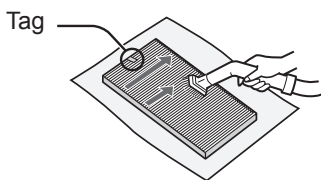

Gently remove dust from HEPA Filter and Deodorizing Filter with a vacuum cleaner attachment or similar tool.

CAUTION

Do not WASH in water and DRY in the sun.
The filters are fragile, be careful not to apply too much force.

Deodorizing Filter

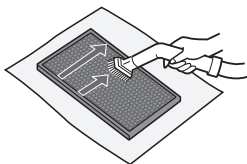

- HEPA Filter
Apply the maintenance only on the side with the tag.
Do not clean the opposite side; otherwise, the filter will be damaged.
- Deodorizing Filter
The maintenance can be applied to the both sides.

SENSORS

Dust sensor

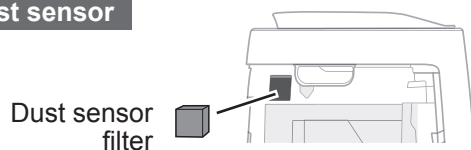

1. Remove the Back Panel.
2. Remove the Dust Sensor Filter.
3. If it is very dirty, wash it with water and dry it thoroughly.

Odor sensor

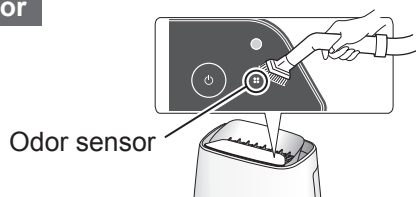

Gently remove dust from the odor sensor, using a vacuum cleaner attachment or similar tool.

UNIT

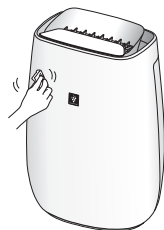

Wipe with a dry, soft cloth

For stubborn stains or dirt, use a soft cloth **dampened with warm water.**

CAUTION

•Do not use volatile fluids

Benzine, paint thinner, polishing powder, etc., may damage the surface.

•Do not use detergents

Detergent ingredients may damage the unit.

REPLACEMENT

Filter

Replacement timing

When Replace Filter Indicator light turn on*

HEPA Filter

Model : FZ-F50HFE

Deodorizing Filter

Model : FZ-F50DFE

*The Replace Filter indicator light will turn on after approximately 17,500 hours (2 years × 24 hours = 17,500).

Conditions: Mode:sleep , Light: Dark ,Dirt: small
Filter life varies depend on the operation mode.

Life of Filters

The filter life and replacement period are based on the condition of smoking 5 cigarettes per day and the dust collection power is reduced by half compared with that of new filter. Filter life varies depending on the room environment, usage, and location of the unit. We recommend to replace the filter more frequently if the product is used in a condition significantly severer than normal household use.

- HEPA Filter : About 2 years after opening
- Deodorizing Filter : About 2 years after opening

Filter replacement indicator

Replace the Filter according to the instructions provided with the replacement filter.

After the exchange, insert the plug in socket and press the POWER ON/OFF button, and OFF TIMER button 3 seconds.

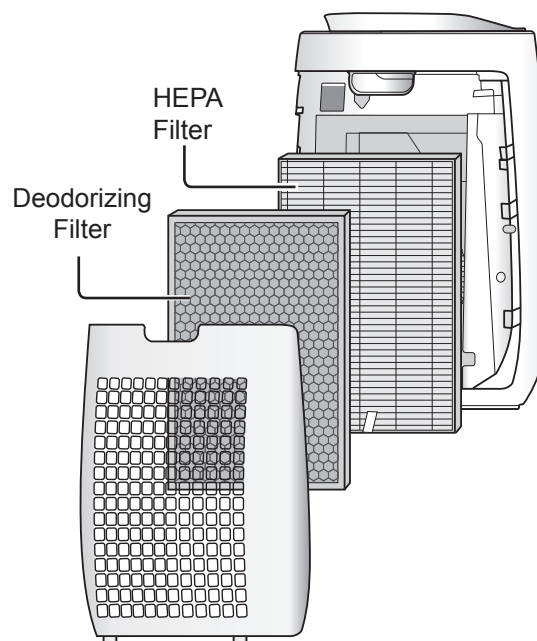
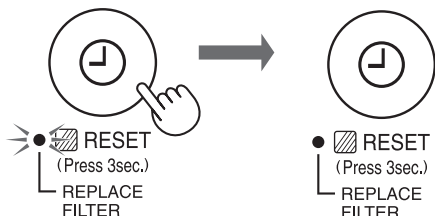

Disposal of Filters

Please dispose of the replaced filter according to the local disposal laws and regulations.

HEPA Filter materials:

- Polypropylene
- Polyethylene

Deodorizing Filter materials:

- Polypropylene
- Polyester
- Activated carbon

TROUBLESHOOTING

Before calling for service, please review the Troubleshooting chart below, since the problem may not be a unit malfunction.





SYMPTOM	REMEDY (not a malfunction)
Odors and smoke are not removed.	<ul style="list-style-type: none"> Replace the filters if they appear to be heavily soiled. (page 9)
The Cleanliness Monitor illuminates blue even when the air is impure.	<ul style="list-style-type: none"> The air could be impure at the time the main unit was plugged in. Unplug the main unit, wait one minute, and plug the main unit in again.
The Cleanliness Monitor illuminates orange or red even when the air is clean.	<ul style="list-style-type: none"> Sensor operation is affected if the dust sensor openings are dirty or clogged. Gently clean the dust sensor openings. (page 8).
A clicking or ticking sound is heard from the main unit.	<ul style="list-style-type: none"> Clicking or ticking sounds may be audible when the main unit is generating ions.
The discharged air has an odor.	<ul style="list-style-type: none"> Check to see if the filters are heavily soiled. Clean or replace the filters. Plasmacluster Air Purifiers emit small traces of ozone which may produce an odor.
The unit does not operate properly when cigarette smoke is in the air.	<ul style="list-style-type: none"> Is the unit installed in a location that is difficult for the sensor to detect cigarette smoke? Is the dust sensor opening blocked or clogged? (In this case, clean the opening.) (page 8)
The Cleanliness Monitor is turned off.	<ul style="list-style-type: none"> Check to see if the Lights OFF Mode selected. Press  for 3 seconds to light On. (page 7) Check to see if the SLEEP mode is selected. The Cleanliness Monitor/ Plasmacluster Ion Light are turned off automatically after the SLEEP mode is selected.
The Cleanliness Monitor lights change color frequently.	<ul style="list-style-type: none"> The Cleanliness Monitor lights automatically change colors as impurities are detected by the dust sensor.
The SLEEP lamp is flashing.	<ul style="list-style-type: none"> Fan motor error. Turn the power OFF. Wait one minute, and then turn the power ON.
AUTO RESTART After a power failure, automatically resume the operation when the power recovers.	Auto Restart can be set. <ul style="list-style-type: none"> Even when the plug is unplugged or the breaker is thrown during the operation, the operation resumes at the previous operation mode and settings if the power recovers.

ON
(with the main unit OFF)



(simultaneously for more than 3 sec.)



If the , , ,  lamp Lights up for 8 seconds, the setting is completed.

OFF
(with the main unit OFF)



(simultaneously for more than 3 sec.)

SPECIFICATIONS

ENGLISH

Power supply		220-240V 50-60Hz		
Fan Speed Operation	Fan Speed Adjustment	MAX	MED	SLEEP*1
	Rated Power	25W	14W	4.0~7.0W
	Fan Speed	240m ³ /hour	186m ³ /hour	48~120m ³ /hour
Recommended Room Size		~30m ² *2		
High density Plasmacluster ion recommended room size		~23m ² *3		
Cord Length		2.0m		
Dimensions		390mm(W)x270mm(D)x583mm(H)		
Weight		6.2kg		

- *1 The fan speed is automatically switched depending on the amount of impurities in the air.
- *2 Size of a room which is appropriate for operating the unit at maximum fan speed.
 - It indicates the space where a certain amount of dust particles can be removed in 30 minutes(JEM1467).
- *3 Size of a room in which approximately 7000 ions can be measured per cubic centimeter in the center of the room (at a height of approximately 1.2 meters from the floor) when the product is placed next to a wall and run at the MED operation position.

Standby Power

In order to operate the electrical circuits while the power plug is inserted in the wall outlet, this product consumes about 0.8W of standby power.
For energy saving, unplug the power cord when the unit is not in use.

SHARP
SHARP CORPORATION
OSAKA, JAPAN

Printed in Thailand
TINS-B147KKRZ 18G- ①