

SHARP®

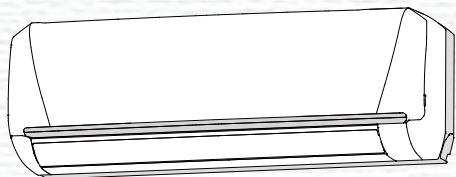

R32



SPLIT TYPE ROOM AIR CONDITIONER OPERATION MANUAL

分体式室内空调机
使用说明书

INDOOR UNIT

(Premium models)

AH-XP*D

AH-XP*F

(Standard models)

AH-X*D

AH-XS*F

OUTDOOR UNIT

AU-X*D

AU-XP*F

AU-X*D

AU-XS*F



"Plasmacluster" and "Device of a cluster of grapes" are registered trademarks or trademarks of Sharp Corporation.

ENGLISH

中文

CONTENTS

• IMPORTANT SAFETY INSTRUCTIONS.....	EN-1
• PART NAMES (UNIT)	EN-2
• PART NAMES (REMOTE CONTROL).....	EN-3
• USING THE REMOTE CONTROL.....	EN-4
• AUXILIARY MODE	EN-5
• TIPS ON SAVING ENERGY	EN-5
• OPERATION CONDITION	EN-5
• BASIC OPERATION.....	EN-6
• ADJUSTING THE AIR FLOW DIRECTION.....	EN-7
• POWERFUL JET / SUPER JET OPERATION	EN-8
• PLASMACLUSTER OPERATION	EN-8
• LOCK ON SENSOR OPERATION.....	EN-9
• BABY MODE OPERATION	EN-9
• ECO MODE OPERATION.....	EN-10
• BEST SLEEP OPERATION	EN-10
• TIMER OPERATION.....	EN-11
• SELF CLEAN OPERATION	EN-12
• MAINTENANCE	EN-12
• LIGHTING BAR.....	EN-13
• BEFORE CALLING FOR SERVICE.....	EN-14
• BEFORE CALLING FOR SERVICE (GET THE ERROR CODE).....	EN-15

IMPORTANT SAFETY INSTRUCTIONS

WARNING

- Do not pull or deform the power supply cord. Pulling and misuse of the power supply cord can result in damage to the unit and cause electrical shock.
- Be careful not to expose your body directly to the outlet air for a long time. It may affect your physical conditions.
- When using the air conditioner for infants, children, elderly, bedridden, or disabled people make sure the room temperature is suitable for those in the room.
- Never insert objects into the unit. Inserting objects can result in injury due to the high speed rotation of internal fans.
- Ground the air conditioner without fail. Do not connect the grounding wire to gas pipe, water pipe, lightning rod or telephone grounding wire. Incomplete grounding may cause electric shock.
- If anything is abnormal with the air conditioner (ex. a burning smell), stop the operation immediately and turn the circuit breaker OFF.
- The appliance shall be installed in accordance with national wiring regulations. Improper cable connection can cause the power supply cord, plug and the electrical outlet to overheat and cause fire.
- If the supply cord is damaged, it must be replaced by the manufacturer or its service agent or a similarly qualified person in order to avoid a hazard. Use only the manufacture-specified power cord for replacement.
- Do not splash or pour water directly on the unit. Water can cause electrical shock or

equipment damage.

- Do not attempt to install/remove/repair the unit by yourself. Incorrect work will cause electric shock, water leak, fire etc. Consult your dealer or other qualified service personnel for the installation/removal/repair of the unit.

CAUTION



- Open a window or door periodically to ventilate the room, especially when using gas appliances. Insufficient ventilation may cause oxygen shortage.
- Do not operate the buttons with wet hand. It may cause electric shock.
- For safety, turn the circuit breaker off when not using the unit for an extended period of time.
- Check the outdoor unit mounting rack periodically for wear and to make sure it is firmly in place.
- Do not put anything on the outdoor unit nor step on it. The object or the person may fall down or drop, causing injury.
- This unit is designed for residential use. Do not use for other applications such as in a kennel or greenhouse to raise animals or grow plants.
- Do not place a vessel with water on the unit. If water penetrates into the unit, electrical insulations may deteriorate and cause electric shock.
- Do not block the air inlets nor outlets of the unit. It may cause insufficient performance or troubles.
- Be sure to stop the operation and turn the circuit breaker off before performing any maintenance or cleaning. A fan is rotating inside the unit and you may get injured.
- This appliance is not intended for use by persons (including children) with reduced physical, sensory or mental capabilities, or lack of experience and knowledge, unless they have been given supervision or instruction concerning use of the appliance by a person responsible for their safety. Children should be supervised to ensure that they do not play with the appliance.
- Make sure to connect the air conditioner to power supply of the rated voltage and frequency. Use of a power supply with improper voltage and frequency can result in equipment damage and possible fire.
- Do not install the unit in a place where inflammable gas may leak. It may cause fire. Install the unit in a place with minimal dust, fumes and moisture in the air.
- Arrange the drain hose to ensure smooth drainage. Insufficient drainage may cause wetting of the room, furniture etc.
- Make sure a leak breaker or a circuit breaker is installed, depending on the installation location, to avoid electrical shock.

PART NAMES (UNIT)

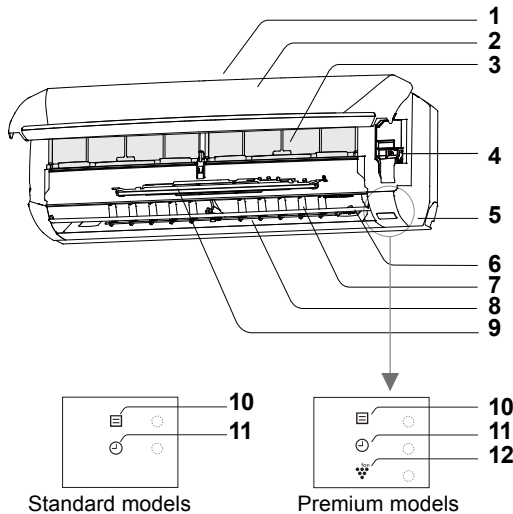
INDOOR UNIT



※ Indoor unit appearance may be different from the image above.

- 1 Inlet (Air)
- 2 Open Panel
- 3 Air Filter
- 4 AUX Button
- 5 Receiver Window
- 6 Vertical Airflow Louver
- 7 Horizontal Airflow Louver
- 8 Outlet (Air)
- 9 Lighting bar (For some Premium models only)
- 10 OPERATION Lamp (green )
- 11 TIMER Lamp (orange )
- 12 PLASMACLUSTER Lamp (blue ) (For Premium models only)

PART NAMES (REMOTE CONTROL)

REMOTE CONTROL

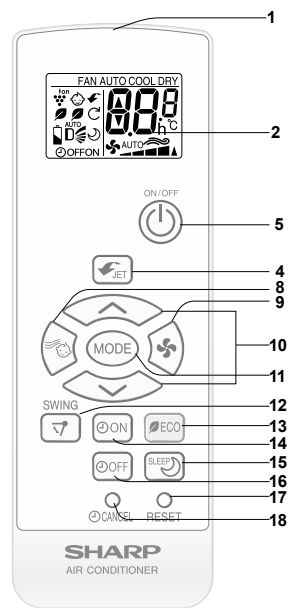
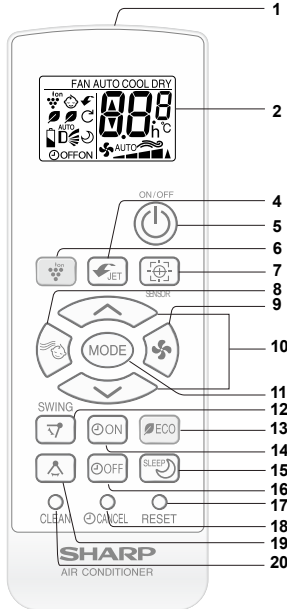
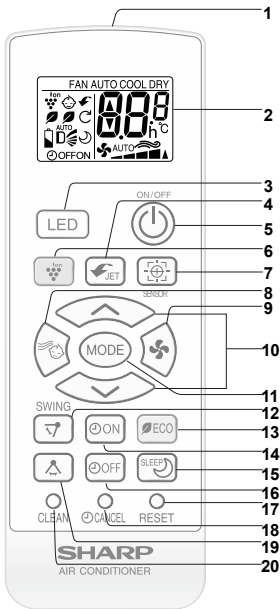

Premium models

Standard models

- | | |
|-----------------------------------|---|
| 1 TRANSMITTER | 12 SWING Button
(↕ : Vertical direction) |
| 2 DISPLAY | 13 ECO Button |
| 3 LED Button | 14 TIMER ON Button |
| 4 POWERFUL JET / SUPER JET Button | 15 BEST SLEEP Button |
| 5 ON/OFF Button | 16 TIMER OFF Button |
| 6 PLASMACLUSTER Button | 17 RESET Button |
| 7 LOCK ON SENSOR Button | 18 TIMER CANCEL Button |
| 8 BABY MODE Button | 19 SWING Button
(↔ : Horizontal direction) |
| 9 FAN Button | 20 SELF CLEAN Button |
| 10 THERMOSTAT Button | |
| 11 MODE Button | |

USING THE REMOTE CONTROL

DISPLAY

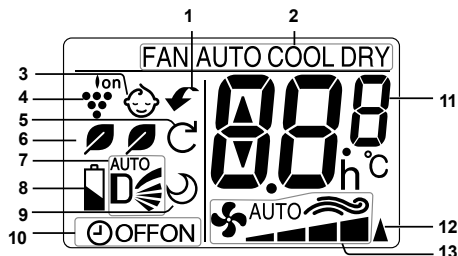

- 1 POWERFUL JET / SUPER JET Symbol
- 2 MODE Symbols
FAN / AUTO / COOL / DRY
- 3 BABY MODE Symbol
- 4 PLASMACLUSTER Symbol
(For Premium models only)
- 5 SELF CLEAN Symbol
(For Premium models only)
- 6 ECO Symbols
- 7 VERTICAL AIR FLOW Symbol
- 8 BATTERY Symbol
- 9 BEST SLEEP Symbol
- 10 TIMER ON / TIMER OFF Indicator
- 11 TEMPERATURE Indicator
- 12 TRANSMITTING Symbol
- 13 FAN SPEED Symbols

 : AUTO

 : Manual setting

LOADING BATTERIES

- 1 Remove the battery cover.
- 2 Insert two batteries. (AAA(R03))
Make sure the (+) and (-) polarities are correctly aligned.
- 3 Reinstall the battery cover.
- 4 Press the RESET button using a thin stick.

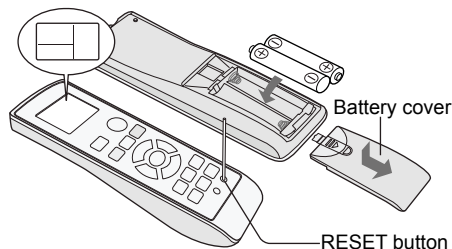

NOTE:

- The battery life is approximately 1 year in normal use.
- Replace the batteries when the remote control displays "🔋".
- When replacing the batteries, always change both and use the same type.
- If you will not be using the unit for a long time, remove the batteries from the remote control.

HOW TO USE THE REMOTE CONTROL

Point the remote control towards the receiver window and press the desired button. The unit generates a beep when it receives the signal.

- Make sure nothing, such as curtains, block the signal receiver window.
- The signal effective distance is 7 m.

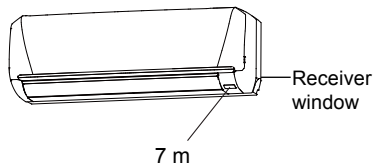

CAUTION:

- Do not expose the receiver window to direct sunlight. This may adversely affect its operation.
- Use of certain fluorescent lamp in the same room may interfere with transmission of the signal.
- Do not leave the remote control in direct sunlight or near a heater. Protect the remote control from moisture and shock.

AUXILIARY MODE

Use this mode when the remote control is not available.

TO TURN ON

Press the AUX button.

- The green OPERATION lamp () will light up and the unit will start operating in the AUTO mode.
- The fan speed and temperature setting are set to AUTO.

TO TURN OFF

Press the AUX button again.

- The green OPERATION lamp () will turn off.

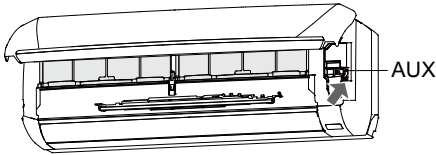

OPERATION CONDITION

Mode		Indoor Temp.	Outdoor Temp.
Cooling	Upper limit	32°C	43°C
	Lower limit	21°C	21°C

- The build-in safety device may prevent the unit from operating when used out of this range.
- Condensation may form on the air outlet if the unit operates continuously in the COOL or DRY mode when humidity is over 80%.

TIPS ON SAVING ENERGY

Below are some simple ways to save energy when you use your air conditioner.

Set the proper temperature

- Setting the temperature lower than necessary during cooling operation will result in increased power consumption.

Block direct sunlight and prevent drafts

- Blocking direct sunlight during cooling operation will reduce power consumption.
- Close the windows and doors during cooling and heating operations.

Keep filter clean to ensure the most efficient operation

Disconnect the power cord when the unit is not used for an extended period time

- The indoor unit still consumes a small amount of power when it is not operating.

BASIC OPERATION

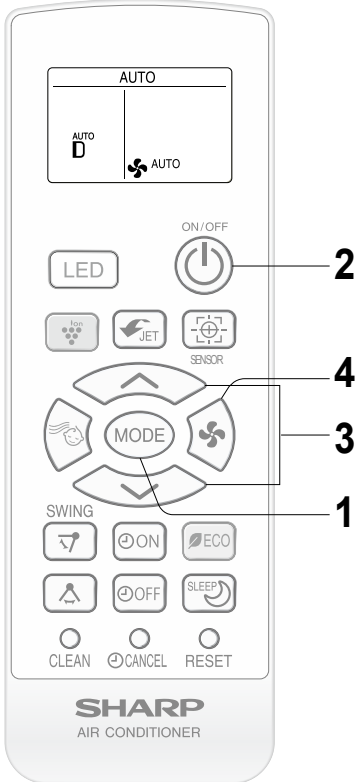

1 Press the **MODE** button to select the operation mode.

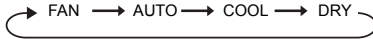

2 Press the **ON/OFF** button to start operation.

- The green OPERATION lamp () will light up.
- The lighting bar will light up to different colors. For more information, refer to page EN-13. (For some Premium models only)

TO TURN OFF

Press the ON/OFF button again.

- The green OPERATION lamp () will turn off.
- The lighting bar will turn off. (For some Premium models only)

3 Press the **THERMOSTAT** button to set the desired temperature, you can set temperature in 0.5 °C increments.

(AUTO/DRY mode)
The temperature can be changed up to $\pm 2.0^{\circ}\text{C}$ from the automatic setting.

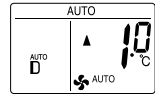

(COOL mode)
The temperature setting range: 14.0-30.0°C.

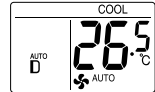

4 Press the **FAN** button to set the desired fan speed.

AUTO BREEZE QUIET SOFT LOW HIGH



In FAN mode, fan speed cannot be set to AUTO.

BREEZE QUIET SOFT LOW HIGH

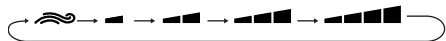

NOTE:

AUTO MODE

In the AUTO mode, the temperature setting and mode are automatically selected according to the room temperature when the unit is turned on.

DRY MODE

The fan speed is preset to AUTO and cannot be changed.

WHEN POWER FAILURE OCCURS

This air conditioner has a memory function to store setting when a power failure occurs.

After power recovery, the unit will automatically restart in the same settings which were active before the power failure, except for TIMER, POWERFUL JET / SUPER JET, BEST SLEEP, BABY MODE, ECO MODE, SELF CLEAN settings.

ADJUSTING THE AIR FLOW DIRECTION

VERTICAL AIR FLOW DIRECTION

1 Press the **SWING** button () to set the desired airflow direction.

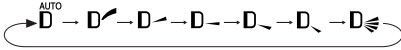

In AUTO mode, airflow direction cannot be set to "D-".

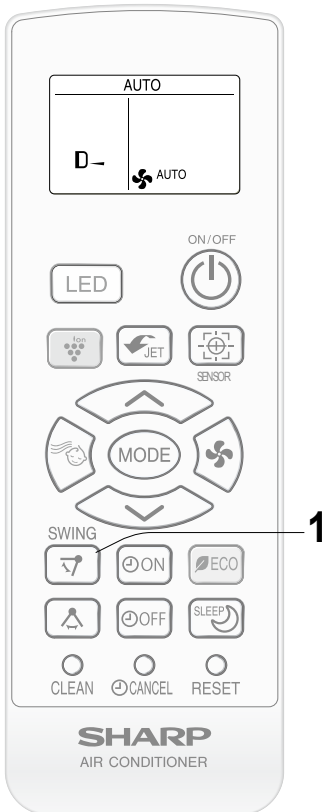
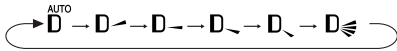

HORIZONTAL AIR FLOW DIRECTION

(For Premium models)

1 Press the **SWING** button ().

- The horizontal airflow louver will swing.
- The lighting bar will wave to show the swing direction.
For more information, refer to page EN-13.
(For some Premium models only)

2 Press the **SWING** button () again to stop at the desired position.

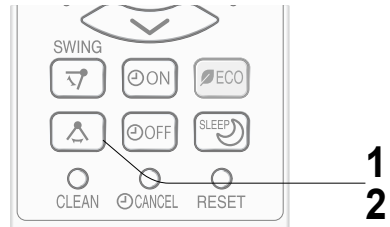

CAUTION:

Never attempt to adjust the louvers manually.

- Manual adjustment of the louvers can cause the unit to malfunction.
- When the vertical adjustment louver is positioned at the lowest position in the COOL or DRY mode for an extended period of time, condensation may result.

NOTE:

- The adjustment range is narrower than the swing range in order to prevent condensation from dripping.

(For Standard models)

Hold the horizontal airflow louver lever and adjust the airflow direction.

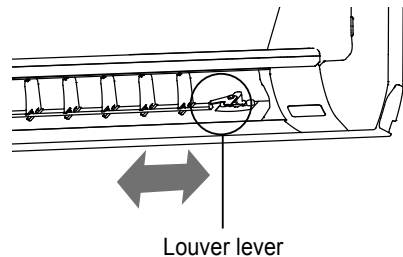

POWERFUL JET / SUPER JET OPERATION

The air conditioner works at the maximum power and optimum louver direction to make the room cool rapidly.

1 During operation, press the POWERFUL JET / SUPER JET button.

- The remote control will display “”.
- The temperature display will go off.
- The vertical airflow louver will be set obliquely downward.
- The lighting bar will turn to blue.
(For some Premium models only)

TO CANCEL

Press the POWERFUL JET / SUPER JET button again.

- The vertical airflow louver will return to the original direction.

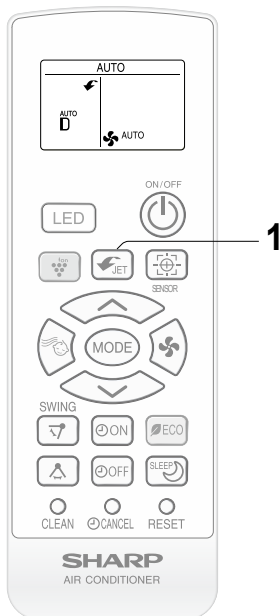



NOTE:

- The air conditioner will operate at “Extra cooling power” and “Extra HIGH” fan speed for 15 minutes, then shift to “HIGH” fan speed.
- You can not set the temperature or fan speed during the POWERFUL JET / SUPER JET operation.

PLASMACLUSTER OPERATION

(For Premium models only)
Plasmacluster ions released into the room will reduce some airborne mold.

1 During operation, press the PLASMACLUSTER button.

- The remote control will display “”.
- The blue PLASMACLUSTER lamp () will light up.

TO CANCEL

Press the PLASMACLUSTER button again.

- The blue PLASMACLUSTER lamp () will turn off.

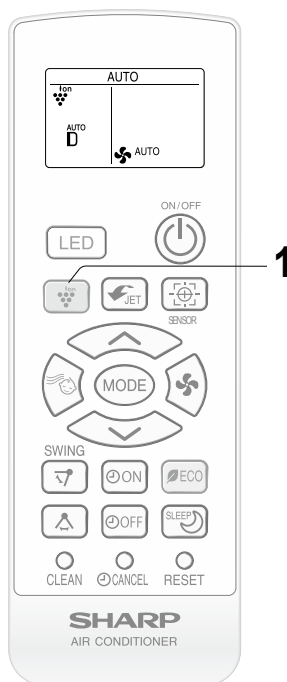

NOTE:

- Use of the PLASMACLUSTER operation will be memorized, and it will be activated the next time you turn on the unit.
- To perform PLASMACLUSTER operation in FAN only mode, press the PLASMACLUSTER button when the unit is not operating. The lighting bar will turn to cool white (For some Premium models only).
The mode symbol of the remote control will go off and the fan speed cannot be set to AUTO.

LOCK ON SENSOR OPERATION

(For Premium models only)

The air conditioner will cool the position of user more effectively in this mode.

1 During operation, press the LOCK ON SENSOR button.

- The sensor will find the position of remote control.
- The horizontal airflow louver angle will be automatically set toward the position of remote control.
- The vertical airflow louver angle will be set obliquely downward.

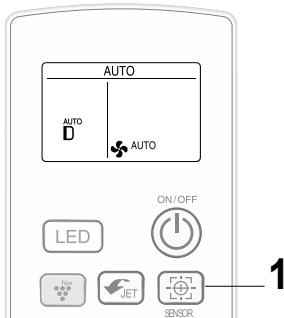

NOTE:

- Make sure the remote control is pointed straight towards the unit's signal receiver window when you press the LOCK ON SENSOR button, otherwise the horizontal airflow louver may not work properly.
- The unit remembers the airflow direction by LOCK ON SENSOR button even after turned off.
- The airflow direction can also be changed with SWING button (↙) (↗). (Refer to EN-7)
- If use the LOCK ON SENSOR button when remote control is very close to the unit, the horizontal airflow louver may get to center position.
- When the distance between the unit and remote control is longer than 5 m, the unit may not detect the position of remote control correctly.

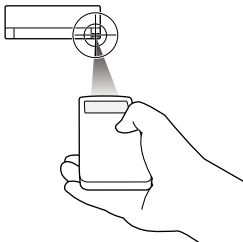

BABY MODE OPERATION

Soft, quiet and clean operation cools a room with well optimized for infants.

1 During operation, press the BABY MODE button.

- The remote control will display “”.
- Fan speed will be automatically set to LOW, SOFT or QUIET.
- Louver will be set to top position (Coanda position).
- PLASMACLUSTER will be turned on. (For Premium models only)
- The lighting bar will turn to pink. (For some Premium models only)

TO CANCEL

Press the BABY MODE button again.

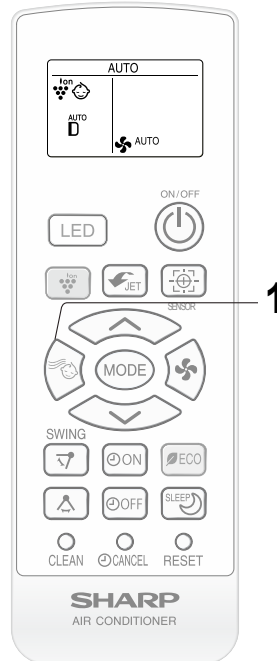

NOTE:

- BABY MODE operation is not available in DRY and FAN mode.

ECO MODE OPERATION

The air conditioner will operate with lower power consumption than usual in this mode.

1 During operation, press the ECO MODE button to enter 1st step power consumption mode.

- The remote control will display “”.
- The lighting bar will turn to green.
(For some Premium models only)

2 Press the ECO MODE button again to enter 2nd step power consumption mode.

- The remote control will display “”.

TO CANCEL

Press the ECO MODE button again during 2nd step power consumption mode.

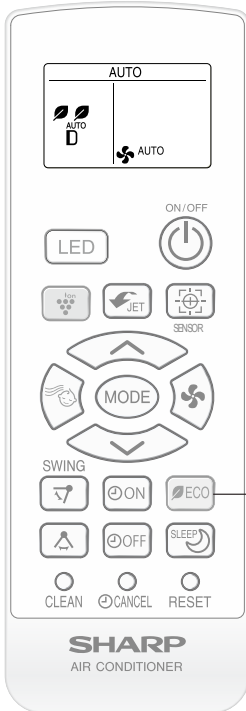

BEST SLEEP OPERATION

For more comfortable sleep, temperature and fan speed will be controlled automatically by the best program.

1 During operation, press the BEST SLEEP button.

- The remote control will display “”.
- Temperature and fan speed will be controlled automatically for the best sleep.
- The lighting bar will turn to orange. After 1h, the light will turn off. For more information, refer to EN-13.
(For some Premium models only)

TO CANCEL

Press the BEST SLEEP button again.

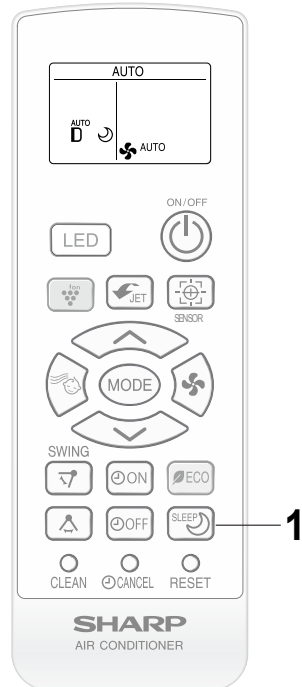

NOTE:

- BEST SLEEP operation is not available in DRY and FAN mode.

TIMER OPERATION

TIMER OFF

- 1** Press the **TIMER OFF** button and set the time as desired.

→0.5h→1.0h→1.5h→10h→11h→12h

- The orange **TIMER** lamp (⏰) will light up.
- The timer setting will count down to show the remaining time.

TO CANCEL

Press the **CANCEL** button.

- The orange **TIMER** lamp (⏰) will turn off.

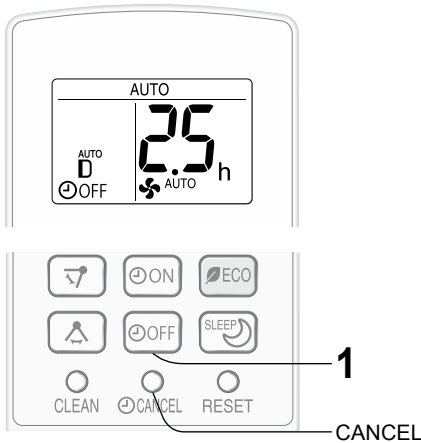

TIMER ON

- 1** Press the **TIMER ON** button and set the time as desired.

→0.5h→1.0h→1.5h→10h→11h→12h

- The orange **TIMER** lamp (⏰) will light up.
- The timer setting will count down to show the remaining time.

TO CANCEL

Press the **CANCEL** button.

- The orange **TIMER** lamp (⏰) will turn off.

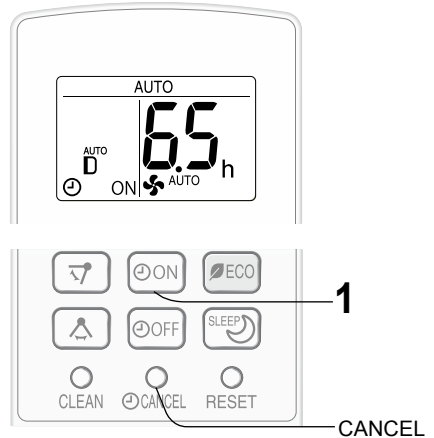

NOTE:

- Timer duration can be set from a minimum half an hour to a maximum of 12 hours. Up to 9.5 hours, you can set in half-hour increments, and from 10 to 12 hours, in 1-hour increments.
- The **TIMER OFF** and **TIMER ON** can not be set together.
- When the temperature is set during timer setting, the temperature will show in the display for 5 seconds and then return to the timer display.
- If a power failure occurs while the **TIMER** is set, the **TIMER** setting will be cancelled and will not be retrieved even after the power is restored.

TIMER ON

- The unit will turn on prior to the set time to allow the room to reach the desired temperature by the programmed time. (Awaking function)

SELF CLEAN OPERATION

(For Premium models only)

SELF CLEAN operation will reduce the growth of mold fungus with Plasmacluster ions and dry inside of the unit. Utilize the operation at seasonal change over terms or every 4 months.

1 Press the **SELF CLEAN** button when the unit is not operating.

- The remote control will display “C”.^{ion}
- The blue PLASMACLUSTER lamp () will light up.
- The lighting bar will turn to cool white. (For some Premium models only)
- The unit will stop operation after 90 minutes.

TO CANCEL

- Press the **SELF CLEAN** button again.
- The blue PLASMACLUSTER lamp () will turn off.

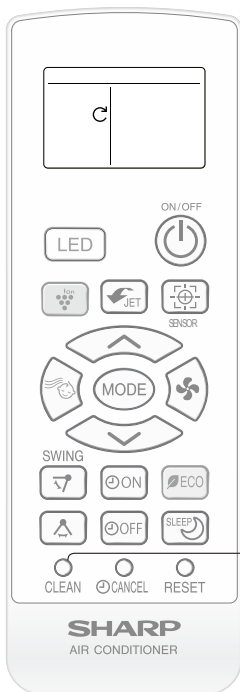

MAINTENANCE

Be sure to disconnect the power cord from the wall outlet or turn off the circuit breaker before performing any maintenance.

CLEANING THE FILTERS

1 Turn off the unit.

2 Remove the filters.

- ① Lift the open panel.
- ② Pull the air filters down to remove them.

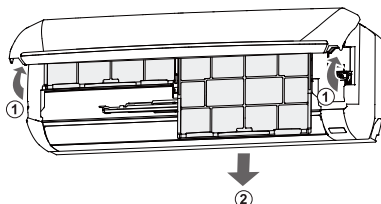

3 Clean the filters.

- Use a vacuum cleaner to remove dust. If the filters are dirty, wash them with warm water and a mild detergent. Dry filters in the shade before reinstalling.

4 Reinstall the filters and close the open panel.

CLEANING THE UNIT AND THE REMOTE CONTROL

- Wipe them with a soft cloth.
- Do not directly splash or pour water on them. It can cause electrical shock or equipment damage.
- Do not use hot water, thinner, abrasive powders or strong solvents.

MAINTENANCE AFTER AIR CONDITIONER SEASON

1 Dry the inside of the indoor unit thoroughly by taking the following steps.

(For Premium models)

Run the unit in the SELF CLEAN operation mode.

(For Standard models)

Run the unit in the COOL mode with temperature setting of 30°C.

2 Stop the operation and unplug the unit.

- Turn off the circuit breaker, if you have one exclusively for the air conditioner.

3 Clean the filters, then reinstall them.

MAINTENANCE BEFORE AIR CONDITIONER SEASON



1 Make sure that the air filters are not dirty.

2 Make sure that nothing obstructs the air inlet or outlet.





LIGHTING BAR

(For some Premium models only)

The lighting bar on the unit turns to different colors to show the operation situation.

OPERATION	COLOR
COOL MODE 	<ul style="list-style-type: none"> Color: Blue or Green When the room temperature is colse to the setting temperature, it turns to green, otherwise it's blue.
DRY MODE 	
AUTO MODE 	
FAN MODE 	
POWERFUL JET / SUPER JET 	<ul style="list-style-type: none"> Color: Blue When Powerful Jet / Super Jet function is started, 5 lights blink 3 times.
PLASMACLUSTER 	<ul style="list-style-type: none"> Color: Cool White Only in FAN only mode.
BABY MODE 	<ul style="list-style-type: none"> Color: Pink
ECO MODE 	<ul style="list-style-type: none"> Color: Green
BEST SLEEP 	<ul style="list-style-type: none"> Color: Orange All of the 5 lights will turn on in the first 10 seconds.  <p>After 10 seconds, just the 1 lights in the middle will keep lighting.</p>  <p>After 20 minutes all the lights will turn off.</p> 
SELF CLEAN 	<ul style="list-style-type: none"> Color: Cool White
LED 	<ul style="list-style-type: none"> Color: White Only after press the LED button when unit is not operating.

The lighting bar also can show the horizontal airflow direction in each mode.

- Swing: 
- Center: 
- Right: 
- Left: 

NOTE:

- When the horizontal airflow direction is swinging, all of the 5 lights will turn on. After the position is decided, the lighting bar will wave to show the direction.

If you think the lighting bar is too bright.

1 Press the LED button and the lighting bar will just keep the middle light in low bright.

2 Press the LED button again and all the lights will turn off.

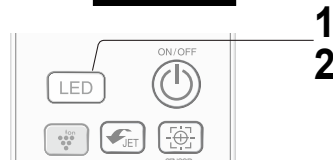
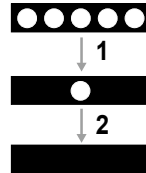

TO CANCEL

Press the LED button again.

If you need some light when the unit is not operating.

1 Press the LED button and the lighting bar will turn on.

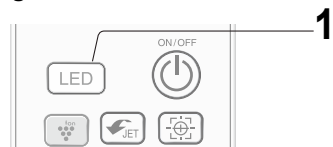

TO CANCEL

Press the LED button again.

BEFORE CALLING FOR SERVICE

The following conditions do not denote equipment malfunctions.

UNIT DOES NOT OPERATE

The unit will not operate if it is turned on immediately after it is turned off. The unit will not operate immediately after the mode is changed. This is to protect the unit. Wait 3 minutes before operating the unit.

ODORS

Carpet and furniture odors that entered into the unit may be sent out from the unit.

CRACKING NOISE

This sound is generated by the friction of the unit expanding or contracting due to a temperature change.

MIST SEEN AT INDOOR AIR OUTLET

In cooling operation, this is caused by the difference between the room air temperature and the air discharged.

THE OUTDOOR UNIT DOES NOT STOP

After stopping the operation, the outdoor unit will rotate its fan for about a minute to cool down the unit.

SWISHING NOISE

The soft, swishing noise is the sound of the refrigerant flowing inside the unit.

(For Premium models only)

ODOR EMITTED FROM THE PLASMACLUSTER AIR OUTLET

This is the smell of ozone generated from the Plasmacluster Ion generator. The ozone concentration is very small, posing no adverse effect on your health. The ozone discharged into the air rapidly decomposes, and its density in the room will not increase.

A LOW BUZZING NOISE

This is a sound of the unit generating Plasmacluster ions.

Check the following points before calling for service.

The unit does not operate

- Check if the circuit breaker has tripped or the fuse has blown.

The unit does not cool effectively

- Check the filters. If dirty, clean them.
- Check the outdoor unit to make sure nothing is blocking the air inlet or outlet.
- Check the thermostat is proper setting.
- Make sure windows and doors are closed tightly.

The unit does not receive the remote control signal

- Check whether the remote control batteries have become old and weak.
- Try to send the signal again with the remote control pointed properly towards the unit's signal receiver window.
- Check whether the remote control batteries are installed properly.

Please call for service when the green OPERATION lamp, the orange TIMER lamp and the blue PLASMACLUSTER lamp on the unit blink.

To describe the malfunction to service, you may find out the error code by the remote control before calling for service.

BEFORE CALLING FOR SERVICE (GET THE ERROR CODE)

ABOUT ERROR CODE

- The error code contains main code and sub code.

Example: error 23-4.

ERROR CODE		
Main Code		Sub Code
23	-	4



GET THE ERROR CODE

Example: error 23-4.

- 1 Press the THERMOSTAT button “” for over 5 seconds on remote control when the indoor unit and remote control is off.

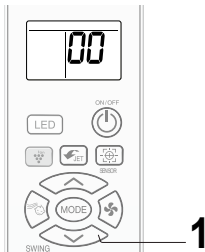
- The remote control will display “00” and there will be a beep sound from the unit’s buzzer.



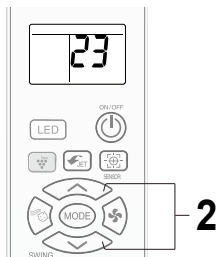

- 2 Press the THERMOSTAT button “” and “”, remote control display will change from “00” to “31” step by step. Meanwhile, buzzer makes a short beep sound on every step.

- When it displays “23”, the buzzer will make a long beep sound to remind you this error code “23” is main error code.

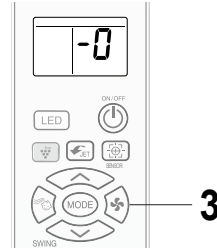

- 3 Press the FAN button once, the remote control will display “-0”.



- 4 Press the THERMOSTAT button “” and “”, remote control display will change from “-0” to “-7” step by step. Meanwhile, buzzer makes a short beep sound on every step.

- When it displays “-4”, the buzzer will make a long beep sound to remind you this error code “4” is sub error code.

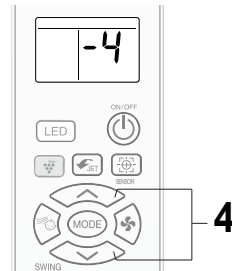

SHARP®